

MANHOLE INVERT CHANNELS: AN OVERVIEW

TECH NOTES



An invert in a manhole is the elevation at which the interior of the incoming and outgoing pipe sits. Yet, it is commonly understood as a channel that runs through the base of the manhole from incoming pipe to out flow pipe. This channel is most typically formed by using a half pipe to form the channel through the base of the manhole. The "half pipe" forming operation creates an unobstructed flow through the manhole.



NPCA

Precast ... The Concrete Solution

INVERT DESIGN

Generally, invert channels will conform to following criteria (see Figure 1):

- Slope of invert bench: 0.5 inch per foot minimum; 1.5 inch per foot maximum;
- Depth of bench to invert: minimum one-half of largest pipe diameter;
- Invert slope through manhole: 1.2 inch drop across manhole with smooth transition of invert through manhole, unless otherwise indicated on construction drawings.

BENCHING

Manhole benching affects the hydraulic flow through the manhole unit during drainage events and sanitary sewer flows. The two most common benching configurations are a half bench and a full bench. In the case of a half bench, the lower half of the pipe shape extends through the manhole while the horizontal benches are extended from the semi-circular channel to the manhole interior wall. A full bench is formed with a full-depth channel, providing improved hydraulics.

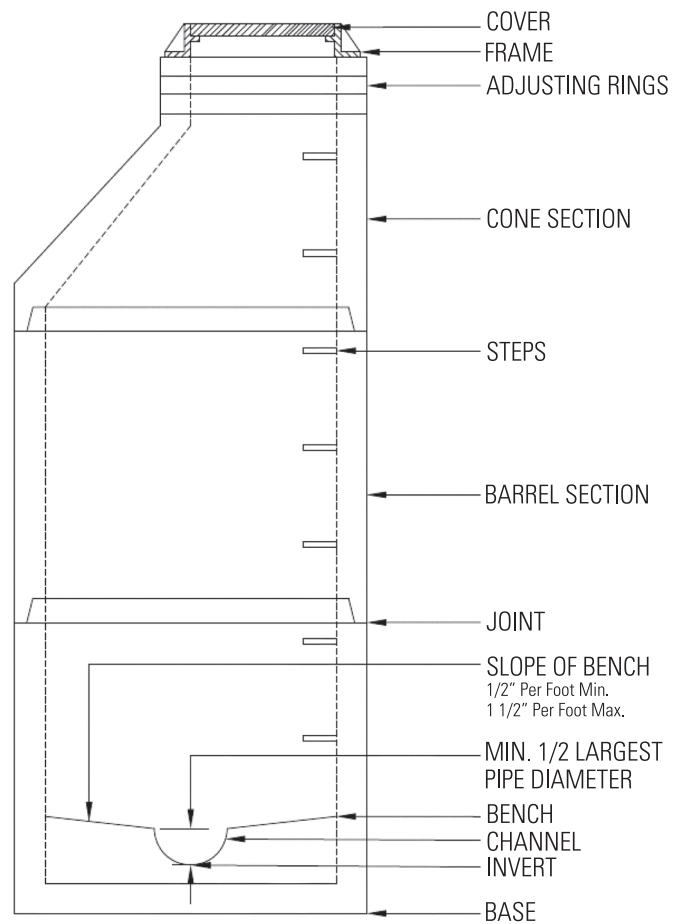

FIGURE 1: A typical manhole section.

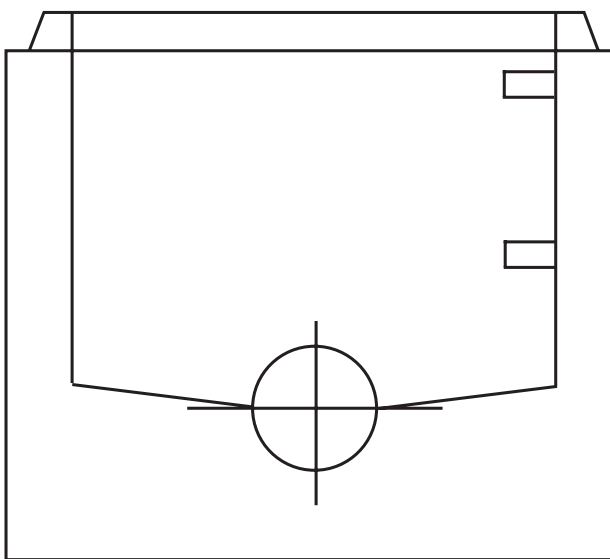

FIGURE 2: Invert channel with half bench.

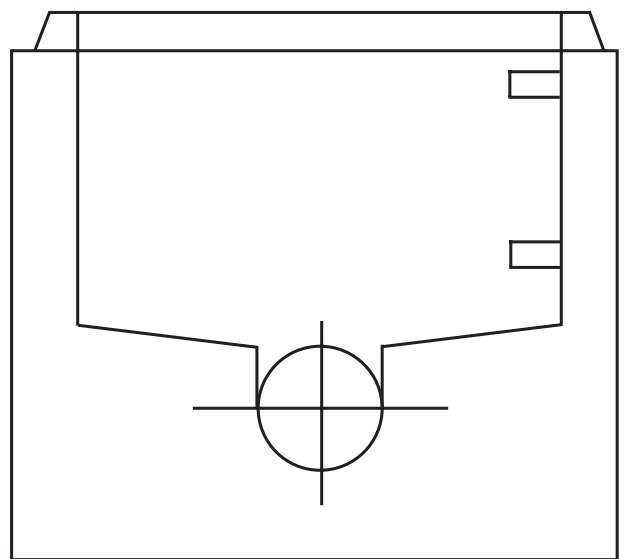

FIGURE 3: Invert channel with full bench.



Typical bench layout before installation.



THE IMPORTANCE OF QUALITY INVERT BENCHING

Scour is defined as degradation of a material due to hydrodynamic forces. It is a specific form of erosion. While concrete is very resistant to scour, stormwater can carry substantial amounts of solids into a storm system and the invert channels may experience scouring from a process known as “shock loading.” Invert channels that are poorly formed or misaligned with the inlet and outlet pipe may tend to trap abrasive solids during a minor drainage event. Severe drainage events will tend to quickly flush these abrasive particles at high velocities resulting in scour abrasion of the invert and bench levels. It is important that

the invert channels and benching are formed with continuous smooth surfaces, manufactured with high quality concrete and then properly aligned when installed.

Inverts are typically formed with a pocket for the pipe to enter the manhole and butt up against the flow channel of the invert (see Figures 2 and 3).

A non-skid finish on the benching may be required to accommodate maintenance and cleaning personnel. This can be accomplished by using a broom finish or applying a non-skid material post-pour.

INSTALLATION

There are several methods used by precasters or contractors to create invert channels in precast concrete manholes. They include installation at the plant and field installation.

INSTALLATION AT THE PRECAST PLANT

- In a primary pour, the channel, base and walls of the manhole are formed monolithically as one casting. This is typically done upside down and then flipped to remove the product from the form, thereby leaving the appropriate channeling.

The minimum concrete thickness from the invert to the bottom of the base slab should be 4 inches, according to ASTM C478 Section 15.3.2.1.

- In a secondary pour, the invert channel is installed in a manhole base. The manhole base and walls will be cast first. When cast monolithically this is often referred to as a mono-base. The hole penetrations for the incoming and outgoing pipes can be formed in the mono-base or they may be cored after the mono-base has cured. The next step is to form the invert channel with form systems that may be fixed or modular. Once the

forming channels have been properly installed and an anti-floatation bar has been secured, the concrete is poured around the suspended channel. These inverts may also be hand-formed. The minimum concrete thickness under the invert channel should be 2 inches, according to ASTM C478 Section 15.3.3.3.

FIELD-POURED MANHOLE BENCHING

In order to ensure the best quality product, inverts should be manufactured in the precast plant along with the manhole section, cured, and then delivered to the site. However, there are specific instances where pouring of inverts must be done in the field. The following precautions should be followed:

- For precast manhole bases, the area underneath the manhole base must be excavated to the required elevation. The soil below the base should not be disturbed, or if fill is required it should be properly compacted. The manhole base is then lowered into the trench and checked for proper bearing on the sub-grade, proper elevation and orientation to receive the incoming and outgoing sewers at the designated invert elevation. The base should be set to the invert elevations specified on the plans. If the base is not set within plan specifications, it may have to be removed and reset.
- The concrete invert will be poured after connecting the sewer pipes to the manhole. The invert must be true to the sewer pipe invert elevations, with smooth channels of uniform cross section and slope, either straight or with a continuous curve between the inlet and outlet of the pipes. The concrete invert should be placed based on the dimensions and details of the contract plans and specifications. Some installers use dirt, brick and other loose material



Monolithic invert mounted on dome.

as the foundation of the invert and then add a thin coat of concrete on the surface. This method should not be used because it does not produce a durable invert, which could lead to future maintenance problems.

- As with invert channels manufactured at the plant, field-poured channels and benching must be constructed only with high-quality concrete. The channels should then be consolidated, finished, cured and properly placed. The minimum concrete thickness must be 2 inches, according to ASTM C478.
- To eliminate free-fall conditions in a manhole resulting from invert elevation differentials between incoming and outgoing pipes, the contractor should form and construct suitable channels in the bottom of the manhole connecting the inverts.

CHANNELIZATION PLAN OF MAINLINE SEWER MANHOLES

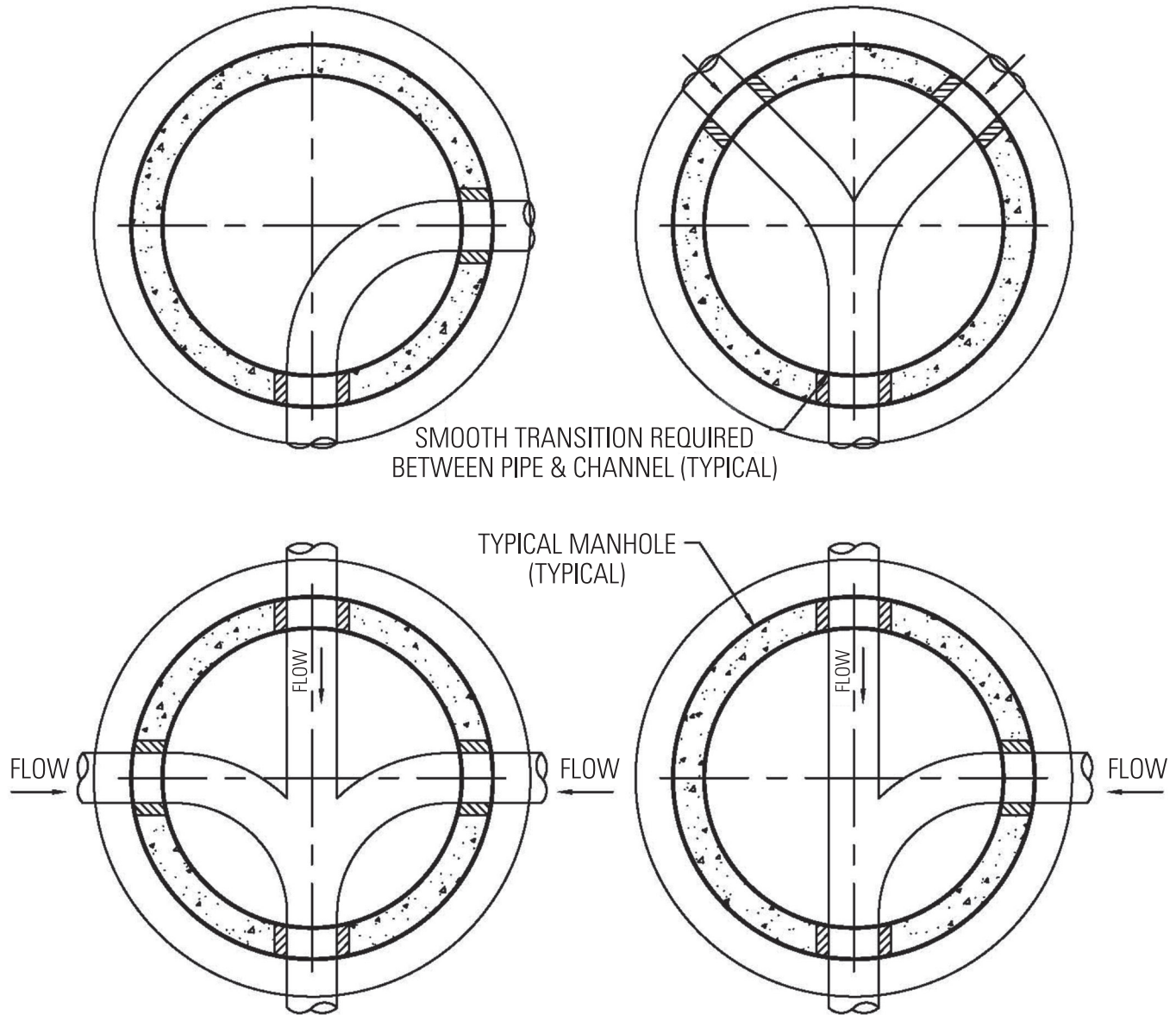

CHANNEL LINING NOTES

- Channel lining must be constructed of properly designed and placed concrete.
- Width of channel should match the inside diameter of incoming and outgoing pipes
- Channel lining should be blended for smooth contour between pipes
- All invert elevations should be shown on the drawings.

This publication is designed to provide accurate and authoritative information, however the National Precast Concrete Association does not guarantee the validity or accuracy of any data, claim or opinion appearing in this publication. If engineering, legal or other professional services are required, the services of a competent professional should be obtained. The National Precast Concrete Association does not assume and hereby disclaims liability to any person for any loss or damage caused by errors or omissions in this publication, regardless of whether such errors result from negligence, accident or any other cause whatsoever.